

THE NEWS
of
East Washington Heights Baptist Church

Reverend Kip B. Banks Sr., Pastor
2220 Branch Avenue SE, Washington, DC 20020
(202) 582-4811, ewhbc@aol.com, www.ewhbc.org

Volume 54

November 2015

Number 11

*Praise the Lord
with*



thankfulness

".. giving thanks always for all things to God the Father in the name of our Lord Jesus Christ, submitting to one another in the fear of God." Eph 5: 20 – 21, NKJV

The Pastor's Message

Climbing Mountains

The Message Isaiah got regarding Judah and Jerusalem: There's a day coming when the mountain of God's House Will be The Mountain— solid, towering over all mountains. All nations will river toward it, people from all over set out for it. They'll say, "Come, let's climb God's Mountain, go to the House of the God of Jacob. He'll show us the way he works so we can live the way we're made." __ Isaiah 2:1-5, MSG

Life can be characterized as climbing a mountain. We set goals, and then as we strive to achieve them we're climbing up the mountain. Once we attain our goals, it is then that we've reached the top of a mountain, and then it's time to climb another mountain. However, some mountains are eternal, like the mountain of our Christian walk. We're always climbing this mountain and prayerfully one day our feet will strike the heavenly Mount Zion and we'll see God face to face.

In the meantime, we're climbing mountains, and every now and then we get to a plateau, where we can stop and take a vista of how far God has brought us. We can look way down over the valleys and storm clouds and see how far we've come, but we can also turn around and look up at the steep climb ahead. As long as we keep the faith, knowing that God is sustaining us, and bringing us each and every step of the way, then everything will be okay.

This month, Lord willing, I will reach one of those plateaus as I celebrate the completion of another decade of life. As I look back over my life, I can see that I have made it to the top of many mountains. These mountains include the mountain of childhood, the mountain of being a teenager, the mountain of finishing college and grad school, the mountain of getting my first job, the mountain of enjoying professional success, the mountain of answering the call into the Gospel ministry, and the mountain of getting married, being a parent and seeing children off to college.

I am eternally grateful to God for allowing me to climb so many mountains. However, I clearly understand there are many more mountains I must climb. They include the internal mountain of spiritual growth and maturity, the mountain of being a good husband and father and the mountain of seeking to be a servant of God after His own heart.

I am praying for the courage and strength to climb these and other mountains and I am praying for you as you climb the mountains of your individual life. Furthermore, I am praying that we, together as a church body, will work together in the year ahead as we climb the mountain of becoming a transformational church. I am praying that if we slip or fall in our climbs, that the Lord will pick-us up, fix the hurts and put us back on the right path ... the path that leads home to Mount Zion. Oh, we might have to climb over the rough side of the mountain sometimes, but as long as Jesus leads, we will get home some day!

Peace and Blessings, __ **Pastor Kip Banks, Sr.**

Linking Up With Jesus

We celebrated our women's week of prayer service, prayer breakfast and women's day worship service, and we remembered survivors of breast cancer and domestic violence. October is Breast Cancer and Domestic Violence Awareness Month.

The celebration began with prayer service on Wednesday, October 21st with Deacon Katie Williams as the worship leader. We had prayers, powerful testimonies, poems, beautiful solos and songs in the Many Chapel. Participants were Deacons Bessie Hill and Fannie Searles, Mrs. Ida Bullock, Ms. Benica McManus and Rev. Elizabeth Wiggins. Rev. Kip B. Banks, Sr. gave remarks and closed with prayer. It was a great night of love and fellowship.

On Saturday, October 24th, the prayer breakfast was equally outstanding. Our worship leader was Mrs. Melba McCannon who provided superb leadership. We linked up with Jesus with the welcome, songs, scriptures, and prayer. The breakfast was delicious and healthy. The participants were Mrs. Gloria Gross, Mrs. Maxine Charles, Mrs. Barbara Robinson, and Mrs. Jean Holmes. After breakfast, Deacon Betty Fralin read the Desiderata and Mrs. Anita Winston provided shocking data on domestic violence. Mrs. McCannon explained ways that we could link up with Jesus through prayer, love, kindness and hope. She also provided literature to reflect on, "God Is the Answer" and "Laugh a Little." We held hands as Rev. Banks closed the service with prayer.

On Sunday, October 25th, Rev. Lisa Maynor delivered an extraordinary sermon at the worship service. She spoke about "The Woman at the Well" and how she linked up with Jesus. All of the women on the pulpit did an exemplary job. Mrs. Rosemary Gary was the worship leader. Other participants were Mrs. Lisa Brown and Ms. Jacqueline Fountain, Mrs. Michelle Glymph, Mrs. Barbara Savage, Mrs. Barbara Robinson, Deacons Katie Williams, Betsy Hill and Mrs. Karen Pugh. Dr. Priscilla Ellerbee gave some significant facts on breast cancer and what we can do to prevent the disease or make early discovery. The women's choir sang beautifully and the ushers under the guidance of Deacon Dr. Zavolia Willis were our grandmothers, mothers, daughters and granddaughters.

A lovely reception was held in Fountain Hall. A special "Thank You" is extended to Ms. Joan Marshman, Mrs. Mary Goodwin, Mrs. Renage Brox-Braxton, Mrs. Doris Smith Simon and Ms. Audrey Stewart. Also, thanks to our musicians, Mrs. Avis Balcom-Williams, Mr. David Dodson and Mr. Dwayne Byrams, Ms. Joyce Milton, our secretary, Ms. Sharon French, caterer, Mrs. Anita Winston for the table enhancements and to Rev. Kip B. Banks, Sr., Pastor of EWHBC.

May God bless all of the EWHBC Congregation, including our friends and guests.

Mrs. Vasser J. Baldwin, Chairperson of the Women's Day Committee



Think About It!

The Power of Gratitude

Gratitude is the quality of being thankful; readiness to show appreciation for, and to return kindness.

Gratitude unlocks the fullness of life. It turns what we have into enough, and more. It turns denial into acceptance, chaos to order, confusion to clarity. It can turn a meal into a feast, a house into a home, a stranger into a friend. Gratitude makes sense of our past, brings peace for today, and creates a vision for tomorrow. __Melody Beattie

Transformations

Gratitude can transform common days into thanksgivings, turn routine jobs into joy, and change ordinary opportunities into blessings __William Arthur Ward

Experiencing gratitude

To be grateful is to recognize the love of God in everything he has given us and he has given us everything. Every breath we draw is a gift of his love. Every moment of existence is a grace, for it brings with it immense graces from him.

Gratitude, therefore, takes nothing for granted, is never unresponsive, is constantly awakening to new wonder and to praise of the goodness of God; for the grateful person knows that God is good not by hearsay but by experience, and that is what makes all the difference. __Thomas Merton

Thanksgiving Beatitudes

Be thankful that you don't already have everything you desire. If you did, what would there be to look forward to?

Be thankful when you don't know something, for it gives you the opportunity to learn.

Be thankful for the difficult times. During those times you grow.

Be thankful for your limitations, because they give you opportunities for improvement.

Be thankful for each new challenge, because it will build your strength and character.

Be thankful for your mistakes. They will teach you valuable lessons.

Be thankful when you're tired and weary, because it means you've made a difference. –Author unknown

Happy Birthday to all who were born in November!

Happy Anniversary to all who were married in November!

THE NEWS

Special Dates in November 2015

- All Saints' Day, Sunday, November 1
 - Daylight-Saving Time ends, Sunday, November 1, 2:00AM
 - 121st Anniversary Celebration, Sunday, November 1, 11:00AM
 - Revival, Wednesday, November 4, 7:00PM, & Thursday, November 5, 7:00PM
 - Veterans Day, Wednesday, November 11
 - Thanksgiving Breakfast and Worship, Thursday, November 26, 8:30AM
 - First Sunday of Advent, November 29,
-

From Harm to Good

Squanto, the Native American who helped the Pilgrims, has a background remarkably similar to that of Joseph in Genesis.

Years before the Pilgrims arrived in America, English traders kidnapped Squanto and other Native Americans and sold them as slaves in Spain. Incredibly, Squanto was bought by monks, who set him free and taught him about Jesus. Later Squanto sailed to England, hoping for passage to America. But he had to wait years, so he worked as a stable hand and learned English. Finally able to travel home, he was devastated to find his tribe wiped out by smallpox.

A couple of years later, the Pilgrims came ashore, tired, sick and having lost many shipmates on the way. Implausibly, they encountered an English-speaking Native American, who shared his friendship and knowledge. Like Joseph going from his homeland to Egypt and from slave to expert leader, Squanto experienced God's leading, even when the path was littered with misfortune.

Using Squanto, God saved a whole community. What some intended for harm, God turned into good (see Genesis 50:20).

Guide My Words A prayer for everyday

Father, I face another day in which I will be called upon to use my words wisely and well. May they encourage those who listen. May they speak truth but also be said in love. May I pause before I pounce. May I be bold enough to speak when I would rather run away. Lord, I give my mouth to you today. May what comes forth be sweet and not bitter. May the journey each word takes from my mind to my heart to my lips be guided by your hand. May what comes out be life-giving rather than causing death. May my words make you proud and bring you glory. In Jesus' name, Amen. __Karen Ehman, *Keep It Shut* (Zondervan)

Have a blessed and peaceful Thanksgiving!

THE NEWS

GIVE ... You have a Lot to GIVE

A good steward will:

Serve

Tithe

Enlist

Win others

Advance

Remember

Dedicate

Sacrifice

Honor

Inspire

Pray.

Stewardship is not a thing of logic; it is a thing of life. It is not the law of God for us; it is the life of God in us.

Pastor Banks Honored by DC Laymen of PNBC

On Saturday, October 17, Pastor Kip Banks was honored by the DC Laymen of the Progressive National Baptist Convention, Inc. at a banquet that was held at the Isle of Patmos Baptist Church of Washington, DC. Rev. Keith Byrd, Pastor of the Zion Baptist Church was the guest preacher.

Pastor Banks was honored for his service as Interim General Secretary of the Progressive National Baptist Convention. Banks served as the Interim operational manager of the convention as the convention searched for a full-time manager, and was replaced in September by Dr. Timothy Boddie who now serves as the fulltime director. The Progressive National Baptist Convention is the church convention of the Rev. Dr. Martin Luther King, Jr.



Food Pantry Contribution

On Sunday, October 25, 2015, Sister Viola Collier-Jones, an East Washington Heights Baptist Church neighbor, made a significant contribution to the church's food pantry. Sister Collier-Jones organized a walk-a-thon and utilized the proceeds from the walk-a-thon to purchase items for the food pantry.

The East Washington Heights Baptist Church food pantry is affiliated with the Capital Area Food Bank and dispenses food to persons in need every 3rd Thursday of the month and serves over 100 families. Please contact Deacon Yvonne Burke at the church office (202-582-4811) if you'd like to volunteer with the pantry.



A Saintly Party

A priest told the children of his parish they could come trick-or-treating at the rectory, but only if they dressed up as a saint. So a group arrived on the eve of All Saints' Day: one dressed as Saint Anthony, one as Saint Joseph, another in a Saint Clare costume ... and then a child dressed as a dog.

"My boy," exclaimed the priest, "you were supposed to come as a saint."
"i did!" Replied the child. "I'm a Saint Bernard."

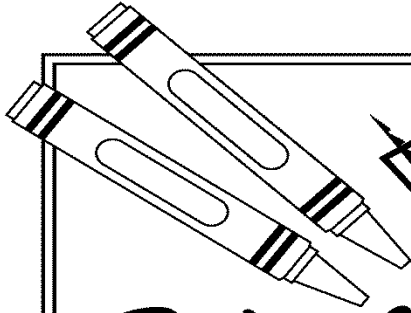

PUZZLE

With all my heart



This Thanksgiving — and every day — let's thank our heavenly Father for all he has done.

Directions: Write the capital letters in order on the lines below to complete Psalm 9:1, NIV.

I	a	W	I	d	L	d	L	G	e
I	f	V	g	h	E	c	T	H	y
A	a	g	N	K	c	m	S	n	T
h	O	q	Y	O	b	U	c	L	O
p	R	e	D	W	a	I	T	H	A
h	L	L	t	M	b	Y	d	H	E
A	R	b	T	d	I	W	I	f	L
g	L	T	E	b	L	c	L	O	j
F	z	A	L	y	L	Y	O	g	U
R	W	d	O	N	t	D	E	f	R
F	U	s	L	D	f	E	E	D	S

“ _____
 _____;
 _____;
 _____”

PSALM 9:1, NIV

Answer: "I will give thanks to you, LORD, with all my heart; I will tell of all your wonderful deeds." Psalm 9:1, NIV